

# ANNALES DE L'I. H. P., SECTION A

PIERRE LOCHAK

## **About the adiabatic stability of resonant states**

*Annales de l'I. H. P., section A*, tome 39, n° 2 (1983), p. 119-143.

[http://www.numdam.org/item?id=AIHPA\\_1983\\_\\_39\\_2\\_119\\_0](http://www.numdam.org/item?id=AIHPA_1983__39_2_119_0)

© Gauthier-Villars, 1983, tous droits réservés.

L'accès aux archives de la revue « Annales de l'I. H. P., section A », implique l'accord avec les conditions générales d'utilisation (<http://www.numdam.org/legal.php>). Toute utilisation commerciale ou impression systématique est constitutive d'une infraction pénale. Toute copie ou impression de ce fichier doit contenir la présente mention de copyright.

NUMDAM

Article numérisé dans le cadre du programme  
Numérisation de documents anciens mathématiques  
<http://www.numdam.org/>

## About the adiabatic stability of resonant states

by

**Pierre LOCHAK**

Centre de Mathématiques de l'École Normale Supérieure,  
45, rue d'Ulm 75230 Paris Cedex 05

---

**ABSTRACT.** — The aim of this paper is to generalize the adiabatic theorem (we recall below the usual statement of the theorem) to « resonant states », i. e. eigenvectors of dilation analytic hamiltonians, for non real eigenvalues. We therefore look at a time-dependant approach of the Balslev-Combes-Simon theory, leading to a non autonomous, non self-adjoint equation, which enables us to prove an asymptotic and a perturbative version of the adiabatic theorem (with the proviso of an extra hypothesis), thus emphasizing the physical character of these states, some features of which we have described.

**RÉSUMÉ.** — Le but de cet article est d'étendre le théorème adiabatique (dont on rappelle l'énoncé usuel) à des états résonants, c'est-à-dire à des vecteurs propres de hamiltoniens analytiques par dilatation, pour des valeurs propres non réelles. On considère une approche dépendant du temps de la théorie de Balslev-Combes-Simon, menant à une équation non autonome non auto-adjointe, et qui permet de démontrer une version asymptotique et perturbative du théorème adiabatique (sous une hypothèse supplémentaire). Cela met en évidence le sens physique de ces états, dont on décrit quelques propriétés.

---

### 1) INTRODUCTION

Although the « phenomenology » of the resonances in scattering experiments is now well known and their mathematical description by means

of « proper differentials », spectral concentration, and above all dilation analyticity techniques is already quite sophisticated, it can be advocated that the corresponding states cannot fit properly in the usual quantum scheme; indeed, the very enunciation of the « rules » of quantum mechanics requires the existence of stationary states, that is, isolated eigenvalues, and however powerful such things as the Fermi Golden Rule may be, they ignore the fact that we lack a theory of quantum transitions; in fact, it is even difficult to speak about quantum « jumps » inside a continuous spectrum, even if one can compute « transition probabilities ».

These physical motivations are carefully analysed in the references [1], where a criterium for the generalization of the « stationary states » is also proposed; and this is adiabatic invariance. Unfortunately, the existing statement of the adiabatic theorem (which we recall below) also requires the existence of an isolated eigenvalue, i. e. a proper stationary state; however, a first generalization was worked out in [2], namely in the case where the hamiltonians depend periodically on time.

The purpose of the present paper is now to investigate a kind of « structural stability » of this theorem; to be precise, the rules of quantization, such as they were already formulated by Schrödinger (see [1] for more details about these physical problems) apply properly only to perfect potentials, leading to discrete spectra. Nature however, provides us only with *non* perfect « potentials wells » which would often eventually lead to completely continuous spectra (because of tunnel effects) in which the usual stationary states (discrete eigenvalues) would be replaced by such phenomena as resonances and spectral concentrations (we again refer to [1] for a physical discussion and examples). It is certainly essential to investigate the significance of the quantum scheme in these non ideal, real cases. In this paper, we carry out this programme in the case of dilation analytic potentials, by extending the adiabatic theorem to the resonant states. One can venture to suppose that the understanding of such phenomena is not only interesting from a mathematical point of view, but might also lead, as is suggested in [1] to a certain insight in the obscure question of quantum transitions; the paper is divided into four parts, which are organized as follows:

(1) Introduction.

(2) Here we introduce the necessary apparatus and prove a theorem which describe the behaviour of certain important semi-groups. This part is preparatory and purely mathematical, and since the meaning of the statements is clear whereas the proofs are rather involved, they can be skipped without impairing further understanding.

(3) The physical states we will be concerned with in the adiabatic theorem are introduced and four properties are given which show that they share some characteristics of the stationary states. The end of that part

deals with a necessary theorem for the existence of the solutions of a certain equation; again, its validity can be taken as granted if one wishes to.

(4) After having recalled the usual version, the adiabatic theorem is stated and proved (two versions) and some remarks added about its significance.

**2) DILATION ANALYTIC POTENTIALS  
AND THE SEMIGROUPS GENERATED  
BY THE DILATED HAMILTONIANS**

For the sake of convenience, I shall make free use of the notations and definitions of [3], which I shall quote thereafter as M. M. M. P. with chapter and paragraph (for instance as regards this part, see especially XII, 5 and XIII, 10). We let:

$$(1) \quad \tilde{H} = - \sum_{k=1}^N (2\mu_k)^{-1} \Delta_k + \sum_{1 \leq i < j \leq N} V_{ij}$$

be the hamiltonian of an N-body quantum system, with two-body  $\Delta$ -compact interactions, that is,  $\tilde{H}$  is an operator on  $L^2(\mathbb{R}^{3N})$  and  $V_{ij} = V_{ij}(r_i - r_j)$  where  $r_i \in \mathbb{R}^3$  is  $\Delta$ -compact as an operator on  $L^2(\mathbb{R}^3)$ . We suppose that  $H \in \mathcal{C}_\alpha$  i. e. that the  $V_{ij}$ 's are dilation analytic in the strip

$$S_\alpha = \{ \theta \in \mathbb{C} ; | \text{Im } \theta | < \alpha < \pi \} ;$$

explicitly, we introduce the unitary group  $(\mathcal{U}(\theta))_{\theta \in \mathbb{R}}$  of dilation operators on  $\mathbb{R}^3$  :

$$(2) \quad \forall \phi \in L^2(\mathbb{R}^3), \quad \forall \theta \in \mathbb{R}; \quad (\mathcal{U}(\theta)\phi)_{(x)} \equiv e^{\frac{3\theta}{2}} \phi(e^\theta x)$$

and we denote by A the generator of this group (the so-called « progress operator ») with spectral resolution  $(dE_\lambda)_{\lambda \in \mathbb{R}}$  :

$$(3) \quad \mathcal{U}(\theta)\phi \equiv e^{-i\theta A} \phi = \int_{-\infty}^{+\infty} e^{-i\lambda\theta} dE_\lambda \phi$$

Letting  $V_\theta \equiv \mathcal{U}_{(\theta)} V \mathcal{U}_{(\theta)}^{-1}$ , the assumption on the  $V_{ij}$ 's is that  $(V_{ij})_\theta$  admits an analytic continuation into an analytic family of  $\Delta$ -bounded (and consequently  $\Delta$ -compact) operators on  $S_\alpha$ . We let H in  $L^2(\mathbb{R}^{3(N-1)})$  be  $\tilde{H}$  with the center of mass removed (see M. M. M. P. XI, 5 for a discussion of this operation) and for  $\theta$  real,  $H_\theta \equiv \mathcal{U}_{(\theta)} H \mathcal{U}_{(\theta)}^{-1}$ . Then,  $H_\theta$  can be continued to  $S_\alpha$  and the Balslev-Combes theorem ([4]) gives the structure of  $\sigma_{(\theta)} \equiv \sigma(H_\theta)$  for  $\theta \in S_\alpha$ . We notice that the theory does not allow one to include external fields, but these can be recovered by letting the mass  $\mu_k$  of one of the particules (which can be viewed as a nucleus) tend to infinity.

We want to view  $\mathcal{U}(\theta)$  ( $0 < | \text{Im } \theta | < \alpha$ ; especially  $\theta = i\beta$  with  $0 < \beta < \alpha$ )

as an unbounded change of representation on  $\mathcal{H} \equiv L^2(\mathbb{R}^{3(N+1)})$ , so that we can later study the dynamics in this new representation; we therefore state an important preparatory theorem in which we also include a few well-known statements, thus obtaining a rather complete description of the semi-groups generated by the dilated hamiltonians:

**THEOREM.** — We denote by  $\mathcal{D}$  the — dense — subset of the analytic vectors for  $\mathbf{A}$ , by  $\mathcal{D}_\alpha$  the set of  $\phi \in \mathcal{H}$ , such that  $\mathcal{U}(\theta)\phi$  exists for  $|\text{Im } \theta| < \alpha$  and by  $\mathcal{D}(\mathcal{U}(\theta))$  the domain of  $\mathcal{U}(\theta)$ ; then, for  $\mathbf{H} \in \mathcal{C}_\alpha$  :

i) The semigroups  $e^{-it\mathbf{H}_\theta}$  ( $t \geq 0, 0 \leq \text{Im } \theta < \alpha$ ) exist and can be continued into a holomorphic family of semigroups for complex values of  $t$  such that  $|\text{Arg } t| < 2 \text{Im } \theta$ .

ii)  $e^{-it\mathbf{H}_\theta}$  is analytic with respect to  $\theta$  for  $0 < \text{Im } \theta < \alpha$  and strongly continuous along  $\text{Im } \theta = 0$ .

iii) Let  $\tilde{\beta}$  be such that  $0 < \tilde{\beta} < \alpha$ ; there exists a positive constant  $M$  such that:

$$(4) \quad \| e^{-it\mathbf{H}_\theta} \| \leq e^{M \cdot \text{Im } \theta \cdot t} \quad \text{for} \quad t \geq 0, \quad 0 \leq \text{Im } \theta \leq \tilde{\beta}$$

Besides, the semigroups  $e^{-it\mathbf{H}_\theta}$  ( $t \geq 0; 0 \leq \text{Im } \theta < \alpha$ ) are of type zero.

iv) The following intertwining relation takes place:

$$\forall \psi \in \mathcal{D}_\alpha, \quad \forall t \geq 0, \quad e^{-it\mathbf{H}}\psi \in \mathcal{D}(\mathcal{U}(\theta)) \quad \text{for} \quad |\text{Im } \theta| < \alpha$$

and

$$(5) \quad \mathcal{U}(\theta)e^{-it\mathbf{H}}\psi = e^{-it\mathbf{H}_\theta}\mathcal{U}(\theta)\psi$$

*Proof.* — i) This first statement is known (M. M. M. P. XII, 5) using the Hille-Philips-Yosida theorem; to apply this theorem, one needs to evaluate:

$$\text{Re} \langle \psi, -i\mathbf{H}_\theta\psi \rangle \equiv \text{Im} \langle \psi, \mathbf{H}_\theta\psi \rangle$$

We do this in the case of a two-body problem with  $\theta = i\beta$  ( $\beta > 0$ ); the generalization is straightforward. One has:

$$\begin{aligned} \mathbf{H}_\theta &= -e^{-2i\beta}\Delta + \mathbf{V}_{i\beta} \\ \text{Re} \langle \psi, -i\mathbf{H}_{i\beta}\psi \rangle &= \sin 2\beta \cdot \langle \psi, \Delta\psi \rangle + \text{Im} \langle \psi, \mathbf{V}_{i\beta}\psi \rangle \end{aligned}$$

An easy interpolation lemma (see M. M. M. P. XII, 5; in Simon words it shows that  $\mathcal{C}_\alpha \subset \mathcal{F}_\alpha$ , his class of dilation analytic potentials for quadratic forms) now proves that  $\mathbf{V}_{i\beta}$ , being  $\Delta$ -compact (hence  $\varepsilon$ - $\Delta$ -bounded generates an  $\varepsilon$ - $\Delta$ -bounded quadratic form i. e.:

$$\forall \varepsilon > 0, \quad \exists b_{(\varepsilon)} > 0, \quad |\text{Im} \langle \psi, \mathbf{V}_{i\beta}\psi \rangle| \leq -\varepsilon \langle \psi, \Delta\psi \rangle + b \|\psi\|^2$$

taking  $\varepsilon < \sin 2\beta$  finishes the evaluation needed to apply the Hille-Philips-Yosida theorem and also demonstrates the existence of the analytic continuation.

ii) The new and important thing here is the behaviour of  $e^{-itH_\theta}$  when  $\theta$  goes down to the real axis. First  $e^{-itH_\theta}$  admits the following representation, as a contour integral:

$$(6) \quad \forall \varphi \in \mathcal{H} : \quad e^{-itH_\theta} \varphi = -\frac{1}{2i\pi} \int_{\Gamma_\beta} e^{-it\lambda} (\lambda - H_\theta)^{-1} \varphi d\lambda$$

where  $\beta \equiv \text{Im } \theta > 0$  and  $\Gamma_\beta$  is pictured on figure I.  $\sigma_{(\theta)}$  is included in the shaded strip; because the  $V_\theta$ 's generate  $\varepsilon$ - $\Delta$ -bounded quadratic forms, the image of  $\langle \psi, H_\theta \psi \rangle$  can be included in a sector  $S$  with arbitrary small opening angle, containing this strip. Lastly the two straight lines of  $\Gamma_\beta$

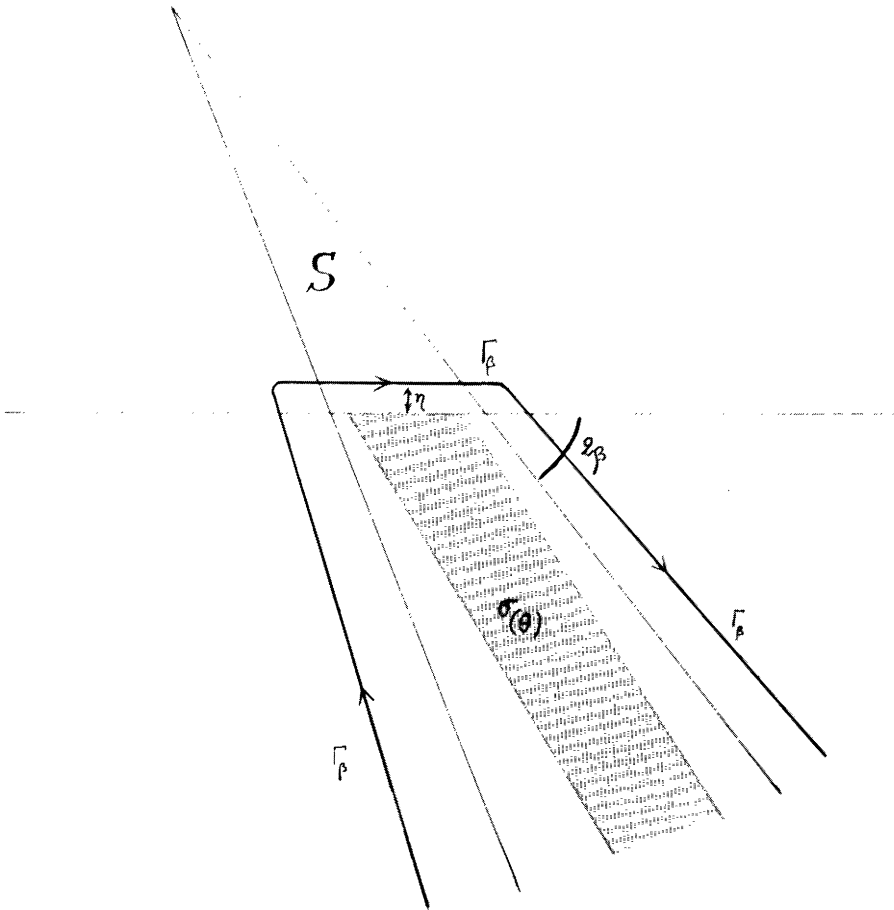

FIG. 1.

going to infinity both diverge from S. The convergence of the integral in (6) is now plain from the estimation:

$$(6 \text{ bis}) \quad \exists M > 0, \quad \forall \lambda \in \mathbb{C} \setminus S, \quad \|(\lambda - H_\theta)^{-1}\| \leq \frac{M}{\text{dist}(\lambda, S)}$$

which is a consequence of the location of the image of  $\langle \psi, H_\theta \psi \rangle$ .

This representation gives an explicit expression of  $e^{-itH_\theta}$  that can be continued for the complex  $t$ 's described in (i). Then, since the *same* path  $\Gamma_\beta$  can be used in a small neighbourhood of  $\theta$ , because of the divergence of the two lines, it proves the analyticity of  $e^{-itH_\theta}$  with respect to  $\theta$ , noting that  $(\lambda - H_\theta)^{-1}$  is analytic on the subset of  $\mathbb{C} \times S_\alpha$  where this resolvent exists, because  $H_\theta$  is an analytic family in the sense of Kato.

The hard part will now be to prove the strong continuity of  $e^{-itH_\theta}$  along  $\text{Im } \theta = 0$  — this is the problem of studying the boundary values of an analytic function. With no loss of generality we put  $\theta = i\beta$  and we let  $\beta$  tend to zero. We write  $V_\beta, H_\beta$  etc... instead of  $V_{i\beta}, H_{i\beta}$  etc... We first need a lemma which says:

LEMMA. —  $\forall \tilde{\beta} < \alpha \quad \|e^{-itH_\beta}\|$  is bounded for  $0 \leq \beta \leq \tilde{\beta} < \alpha$ .

We return to this later and prove the strong continuity assertion:

$$\forall \varphi \in \mathcal{H}^2, \quad \lim_{\beta \rightarrow 0} e^{-itH_\beta} \varphi = e^{-itH} \varphi$$

where, because of the lemma, we restrict ourselves to  $\varphi \in \mathcal{H}^2$ , the domain of  $H$ , which is also the Sobolev space of rank 2.

$\forall \eta \geq 0$  we have:

$$(7) \quad e^{-itH} \varphi - e^{-itH_\beta} \varphi = (e^{-itH} \varphi - e^{-i(t-i\eta)H} \varphi) + (e^{-i(t-i\eta)H} \varphi - e^{-i(t-i\eta)H_\beta} \varphi) + (e^{-i(t-i\eta)H_\beta} \varphi - e^{-itH_\beta} \varphi) \equiv \text{(I)} + \text{(II)} + \text{(III)}$$

— (I) is arbitrarily small, provided  $\eta$  is small enough (independantly of  $\beta$ ).

— We write (II) and (III) as contour integrals on the paths  $\Gamma_{\text{II}}$  and  $\Gamma_{\text{III}}$  pictured on figure 2.

$$(8) \quad \text{(II)} = \frac{1}{2\pi i} \int_{\Gamma_{\text{II}}} e^{-it\lambda} e^{-\eta\lambda} [(\lambda - H)^{-1} \varphi - (\lambda - H_\beta)^{-1} \varphi] d\lambda$$

Then,  $\forall \eta > 0, \forall \varepsilon > 0, \exists \beta_0$  such that (II)  $< \varepsilon$  for  $\beta < \beta_0$  because the resolvents converge uniformly on compact sets.

$$\text{(III)} = e^{-itH_\beta} (e^{-\eta H_\beta} \varphi - \varphi)$$

Again, because of the lemma, we need only to estimate  $(e^{-\eta H_\beta} \varphi - \varphi)$ ; we suppose  $\Gamma_{\text{III}}$  has been taken such that 0 lies inside:

$$- \frac{1}{2\pi i} \int_{\Gamma_{\text{III}}} e^{-\eta\lambda} \lambda^{-1} d\lambda = 1$$

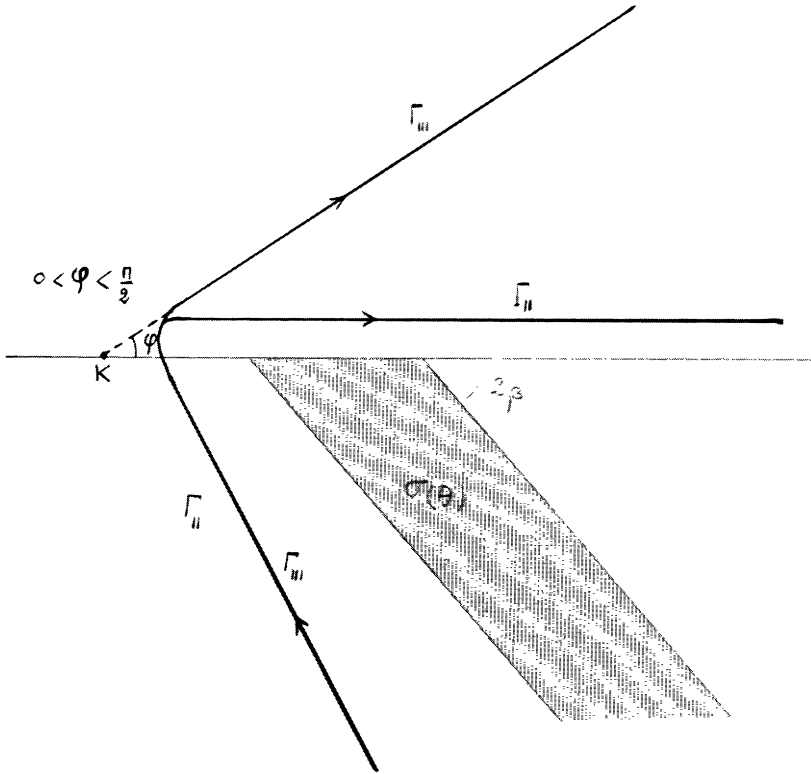

FIG. 2.

Then:

$$(9) \quad (e^{-\eta H_\beta} \varphi - \varphi) = -\frac{1}{2\pi i} \int_{\Gamma_{III}} e^{-\eta \lambda} \lambda^{-1} (\lambda - H_\beta)^{-1} H_\beta \varphi d\lambda$$

We know that  $s - \lim_{\beta \rightarrow 0} H_\beta = H$  and thus  $H_\beta \varphi$  is bounded for  $\beta$  close to zero: moreover;

$$\forall \beta > 0, \quad 0 \leq \beta \leq \tilde{\beta} < \alpha \quad \lim_{\eta \rightarrow 0, \eta \geq 0} e^{-\eta H_\beta} \varphi = \varphi$$

Then, subtracting zero to the previous equality, we get:

$$(10) \quad (e^{-\eta H_\beta} \varphi - \varphi) = -\frac{1}{2\pi i} \int_{\Gamma_{III}} (e^{-\eta \lambda} - 1) \lambda^{-1} (\lambda - H_\beta)^{-1} H_\beta \varphi d\lambda$$

To finish the estimation of (III), i. e. to show that:

$$\forall \varepsilon > 0, \quad \exists (\eta_0, \beta_0), \quad \{ \eta < \eta_0, \beta < \beta_0 \} \Rightarrow \{ (III) < \varepsilon \}$$

we need a uniform estimate (w. r. t.  $\beta$ ) of the resolvent  $(\lambda - H_\beta)^{-1}$  for  $\lambda \in \Gamma_{III}$ .

Since the two branches give rise to similar calculations, we do this only for the upper branch; moreover, we restrict ourselves to the two-body case, the generalization to the N-body case leading only to minor changes. We are thus almost reduced to a computation in [5] and, with a little more care in the evaluations, one gets:

$$(\rho_0, \beta_0), \quad \forall(\rho, \beta), \quad \{ \rho > \rho_0, \beta < \beta_0 \} \Rightarrow \|(\mathbf{H}_\beta - \mathbf{K} - \rho e^{i\varphi})^{-1}\| \leq \frac{16}{\sin \varphi} \cdot \frac{1}{\rho}.$$

This suffices to conclude the proof, with the proviso of the lemma. In fact, take  $\eta_0$  small enough such that (I)  $< \frac{\varepsilon}{3}$  for  $\eta \leq \eta_0$ ; then, reducing  $\eta_0$  if necessary, (III) will be smaller than  $\frac{\varepsilon}{3}$  for  $\beta < \beta_0$ ;  $\eta_0$  being chosen, there exists  $\beta_1 \leq \beta_0$  such that (II)  $< \frac{\varepsilon}{3}$  for  $\beta < \beta_1$ . Combining the three estimates yields:

$$(II) \quad \forall \beta < \beta_1, \quad \|e^{-i\mathbf{H}_\beta} \varphi - e^{-i\mathbf{H}} \varphi\| < \varepsilon$$

We now return to the boundedness of  $(\|e^{-i\mathbf{H}_\beta}\|)_{0 \leq \beta \leq \tilde{\beta}}$ ; of course, we are concerned only with the behaviour near  $\beta = 0$ . We could not find any straightforward demonstration of this fact, which should, however, be easy, considering we will get much more precise informations out of it. We treat again the two-body case, the N-body case being an easy consequence of the demonstration:

$$\mathbf{H}_\beta = -e^{-2i\beta} \Delta + \mathbf{V}_\beta \quad \text{on} \quad \mathcal{H} \equiv \mathbf{L}^2(\mathbb{R}^3)$$

We shall apply the Hille-Phillips-Yosida theorem again, but with a better evaluation of the quadratic form  $\text{Re} \langle \psi, -i\mathbf{H}_\beta \psi \rangle$ . In fact, we will prove:

$$(12) \quad \langle |\text{Im } \mathbf{V}_\beta| \psi, \psi \rangle \leq \beta \langle \mathbf{W} \psi, \psi \rangle \quad \forall \psi \in \mathcal{H}^2$$

with  $\mathbf{W}$  an  $\varepsilon$ - $\Delta$ -bounded potential. Inserting this evaluation in the inequality:

$$\text{Re} \langle \psi, -i\mathbf{H}_\beta \psi \rangle \leq -\sin 2\beta \langle \Delta \psi, \psi \rangle + \langle |\text{Im } \mathbf{V}_\beta| \psi, \psi \rangle$$

proves the lemma, which is equivalent to the boundedness of  $\text{Re} \langle \psi, -i\mathbf{H}_\beta \psi \rangle$  when  $\beta$  goes to zero.

To obtain the estimate (12) which is technical and the proof of which can be skipped if one wants to take it as granted, we need the characterization of dilation analytic potentials, as worked out in [6]. It is easier, for this purpose, to change the dilation group into a multiplicative group, putting:

$$\phi \in \mathbf{L}^2(\mathbb{R}^3), \quad z \in \mathbb{R}, \quad (\mathcal{U}(z)\phi)_{(x)} \equiv z^{3/2} \phi(zx)$$

and simultaneously changing the strip  $S_\alpha$  into the sector:

$$\tilde{S}_\alpha \equiv \{ z = \rho e^{i\varphi}; \quad 0 \leq \rho < \infty, \quad |\varphi| < \alpha \}$$

We consider  $V \in L^2(\mathbb{R}^3)$  as a function (again denoted by  $V$ ):

$$V : \mathbb{R}_+ \rightarrow L^2(\Sigma)$$

where  $\Sigma$  is the unit sphere in  $\mathbb{R}^3$  (change to spherical coordinates). Then, if  $V$  is a dilation analytic potential, it is the restriction to  $\mathbb{R}_+$  of an analytic function  $V$  from  $\tilde{S}_x$  to  $L^2(\Sigma)$  and  $V_z \equiv \mathcal{U}_{(z)} V \mathcal{U}_{(z)}^{-1}$  is simply the restriction of  $V$  to the ray  $\{ \rho z ; \rho \geq 0 \}$  viewed as a function from  $\mathbb{R}_+$  to  $L^2(\Sigma)$ :

$$V_z(\rho) = V_{(z\rho)} \in L^2(\Sigma)$$

And one needs to impose estimates on these functions to ensure that  $V_z$  is  $\Delta$ -compact. To this end, we make use of the following proposition, specific of the dimension 3:

**PROPOSITION.** — *Let  $V \in \mathcal{H}_{loc} \equiv L^2_{loc}(\mathbb{R}^3)$  considered as a multiplication operator on  $\mathcal{H}$ ; the three following statements are equivalent:*

- i)  $V$  is bounded from  $\mathcal{H}^2 = \mathcal{D}(\Delta)$  to  $\mathcal{H}$ .
- ii)  $V$  is  $\varepsilon$ - $\Delta$ -bounded.
- iii)  $\sup_{x \in \mathbb{R}^3} \|V|_{B(x,1)}\|_{L^2} < \infty$  where  $B_{(x,1)}$  is the ball with center  $x$  and radius 1.

Moreover,  $V$  is  $\Delta$ -compact if and only if  $\lim_{|x| \rightarrow \infty} \|V|_{B(x,1)}\|_{L^2} = 0$ .

This enables the authors in [6] to give necessary and sufficient conditions for  $V$  to be a dilation analytic potential. Consider first the case where  $V$  is central; then, it is extended to an analytic function from  $\tilde{S}_x$  to  $\mathbb{C}$ , and the growth condition reads:

$$\forall \varepsilon > 0 \quad \sup_{\substack{-\alpha + \varepsilon \leq \varphi \leq \alpha - \varepsilon \\ \rho \geq 1}} |V(\rho e^{i\varphi})| < \infty$$

We carry out the estimation of  $|\text{Im } V_\beta|$  in this case; this amounts to studying  $|\text{Im } V(\rho e^{i\beta})|$  and we are concerned only with large  $\rho$ 's. Finally, we can restrict ourselves to the case where, for some strictly positive  $\varepsilon$ :

$$0 \leq \beta \leq \frac{\alpha}{2} - \varepsilon < \alpha < \Pi$$

Then, one can write (since  $V(\rho)$  is real for real  $\rho$ ):

$$\begin{aligned} (13) \quad |\text{Im } V(\rho e^{i\beta})| &= \beta \left| \text{Im} \frac{V(\rho e^{i\beta}) - V(\rho)}{\beta} \right| \\ &= \beta \left| \text{Im} \frac{1}{\beta} \int_{z=0}^{z=\rho e^{i\beta}} V'_{(z)} dz \right| \leq \beta \cdot \rho \cdot \sup_{0 \leq \varphi \leq \beta} |V'(\rho e^{i\varphi})| \end{aligned}$$

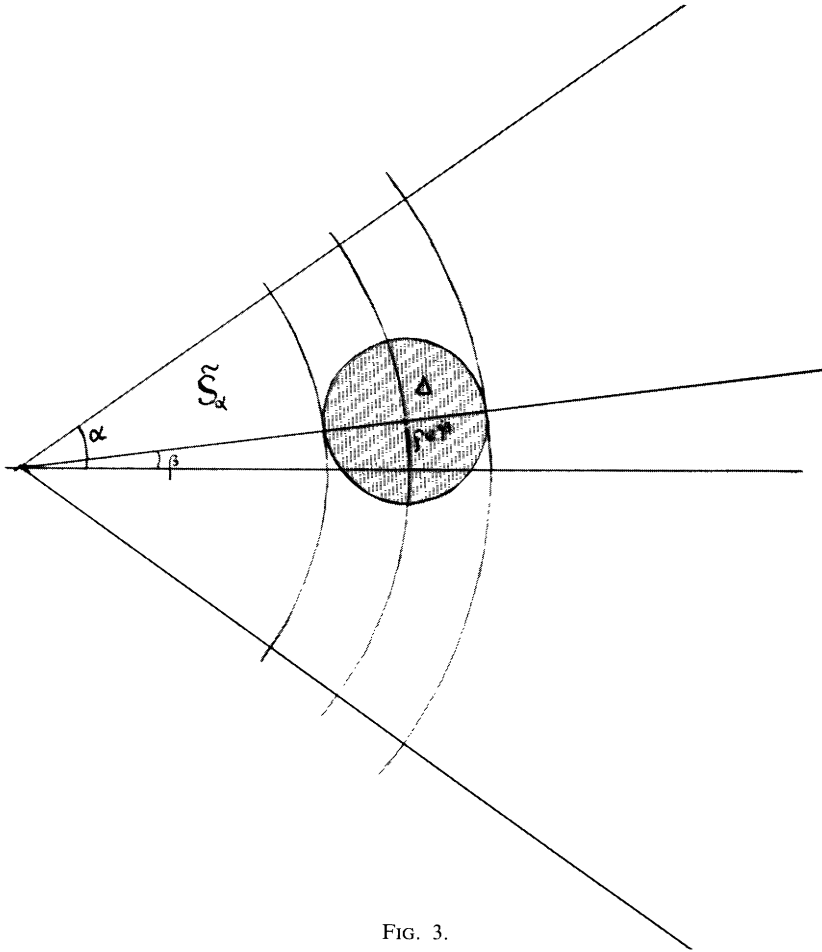

FIG. 3.

But, upon integrating  $V'$  on the disc  $\Delta$  of center  $z = \rho e^{i\varphi}$  and radius  $\rho \sin \frac{\alpha}{2}$  (see figure 3):

$$V'_{(z)} = \frac{1}{2i\pi} \int_{\partial\Delta} \frac{V(u)}{(u-z)^2} du \Rightarrow |V'_{(z)}| \leq \frac{1}{\rho \sin \frac{\alpha}{2}} \sup_{u \in \Delta} |V(u)|$$

Combining the two yields:

$$(14) \quad |\operatorname{Im} V(\rho e^{i\beta})| \leq \beta \cdot \frac{1}{\sin \frac{\alpha}{2}} \cdot \sup_{\substack{-\alpha+\varepsilon \leq \varphi \leq \alpha-\varepsilon \\ \rho(1-\sin \frac{\alpha}{2}) \leq r \leq \rho(1+\sin \frac{\alpha}{2})}} |V(re^{i\varphi})|$$

which proves our contention (12), because of the growth condition on  $V$ .

The case of a non central potential is messier but can be handled similarly; however, one needs a slight improvement of the characterization given in [6]; in fact, one can prove that the following estimate always holds:

$$(15) \quad \sup_{\substack{-\alpha + \varepsilon \leq \varphi \leq \alpha - \varepsilon \\ \rho \geq 1; \sigma \in \Sigma}} \rho \cdot \|V(\rho e^{i\varphi})|_{\Sigma(\sigma, \rho)}\|_{L^2(\Sigma)} < \infty$$

with (as in [6]):  $\Sigma(\sigma, \rho) \equiv \left\{ \sigma' \in \Sigma; d(\sigma, \sigma') \leq \frac{1}{\rho} \right\}$

We will not prove this, which is done again by means of contour integrals; neither shall we go into the proof of the lemma in the non central case, which is rather easy, but gives rise to a very cumbersome notation. The idea is that of the central case.

Thus, the proof of assertion (ii) of the theorem is completed.

iii) First, the semi-groups are of type zero, i. e.:

$$(16) \quad \forall \theta, 0 \leq \text{Im } \theta < \alpha, \forall \eta > 0, \exists M_{\eta, \theta} > 0, \forall t \geq 0, \|e^{-itH_\theta}\| \leq M_{\eta, \theta} e^{-\eta t}.$$

This is obtained readily from the representation by the contour integral (6); one has  $|e^{-it\lambda}| \leq e^{-\eta t}$  on the part of  $\Gamma_\beta$  in the upper half plane and  $|e^{-it\lambda}| \leq 1$  on the part in the lower half plane. Together with (6 bis) this proves (16), because  $\eta$  is arbitrary. Alternatively, (16) reflects the fact that the spectrum of  $H_\theta$  lies below the real axis, which imply that  $e^{-itH_\theta}$  has 0 spectral radius.

We now come to the main point. Let  $\tilde{\beta}$  be an arbitrary positive number  $0 < \tilde{\beta} < \alpha$  and consider the function:

$$(17) \quad \theta \xrightarrow{\sigma} \langle \varphi, e^{-itH_\theta} \psi \rangle$$

with  $0 \leq \text{Im } \theta \leq \tilde{\beta}, \quad \|\varphi\| = \|\psi\| = 1.$

$\sigma$  is holomorphic on the strip  $0 < \text{Im } \theta < \tilde{\beta}$  and continuous on the boundary (this is the assertion of (ii) for the line  $\text{Im } \theta = 0$ ). Moreover:

$$\begin{aligned} -|\sigma(\theta)| &\leq 1 & \text{for } \text{Im } \theta = 0. \\ -|\sigma(\theta)| &\leq \|e^{-itH_{\tilde{\beta}}}\| & \text{for } \text{Im } \theta = \tilde{\beta}. \end{aligned}$$

because of the relation:

$$(18) \quad e^{-itH_{\theta+\varphi}} = \mathcal{U}(\varphi) e^{-itH_\theta} \mathcal{U}(\varphi)^{-1} \quad \text{if } \varphi \in \mathbb{R}$$

then, by the Hadamard three line theorem, we conclude:

$$0 \leq \text{Im } \theta \leq \tilde{\beta}; \quad |\sigma(\theta)| \leq \|e^{-itH_{\tilde{\beta}}}\|^{\frac{\text{Im } \theta}{\tilde{\beta}}}$$

and, since  $\varphi$  and  $\psi$  were arbitrary:  $\|e^{-itH_\theta}\| \leq \|e^{-itH_{\tilde{\beta}}}\|^{\frac{\text{Im } \theta}{\tilde{\beta}}}.$

That there exists  $b(\tilde{\beta})$  such that  $\|e^{-itH_{\tilde{\beta}}}\| \leq e^{b(\tilde{\beta})t}$  is easy to prove (in

fact, the very existence of the semigroup already entails it). Letting  $M \equiv \tilde{\beta}^{-1} \cdot b(\tilde{\beta})$ , we get the inequality as written in (iii).

It is worth noting that the above demonstration applies also to non local potentials (magnetic fields for instance) as soon as one can prove the assertion about the strong continuity along  $\text{Im } \theta = 0$ , and gives probably the best possible bound in the general case.

$$(19) \quad \begin{aligned} & \forall \varphi, \psi \in \mathcal{D}_x, \quad \forall \theta \in S_x, \quad \forall t \geq 0 \\ & \langle \mathcal{U}(-\bar{\theta})\varphi, e^{-itH}\psi \rangle = \langle \varphi, e^{-itH_0}\mathcal{U}(\theta)\psi \rangle \end{aligned}$$

by analytic continuation from  $\text{Im } \theta = 0$ . What we want to show is that  $e^{-itH}\psi \in \mathcal{D}(\mathcal{U}(\theta))$  if  $\psi \in \mathcal{D}_x$  and  $\theta \in S_x$ . We let again  $\theta = i\beta$  ( $0 < \beta < \alpha$ ) and take any  $\psi$  in  $\mathcal{D}_x$ ; then, the relation above reads:

$$\forall \varphi \in \mathcal{D}_x, \quad \langle \mathcal{U}(i\beta)\varphi, e^{-itH}\psi \rangle = \langle \varphi, e^{-itH_\beta}\psi \rangle$$

This extends to  $\varphi \in \mathcal{D}(\mathcal{U}(i\beta))$  because  $\mathcal{D}_x$  is dense in  $\mathcal{D}(\mathcal{U}(i\beta))$  endowed with the graph norm of  $\mathcal{U}(i\beta)$  (this is easy, using the abstract form  $\mathcal{U}(i\beta) = \exp(\beta A)$ ); what this says is:

$$(20) \quad e^{-itH}\psi \in \mathcal{D}(\mathcal{U}(i\beta)^*) \quad \text{and} \quad \mathcal{U}(i\beta)^*[e^{-itH}\psi] = e^{-itH_\beta}\mathcal{U}(i\beta)\psi$$

but this finishes the proof, because  $\mathcal{U}(i\beta) = e^{\beta A}$  is self-adjoint. This fact may be deeper than it looks; for instance, we leave it to the reader to translate the fact that  $\mathcal{U}(i\beta)$  is closed: one is lead to a Phragmen-Lindelöf type interpolation lemma, which is already non trivial.

We have thus completed the proof of the theorem, and we now turn our interest towards the states we will need for the proof of an adiabatical theorem.

### 3) THE RESONANT STATES CHARACTERIZATIONS

We put again  $\theta = i\beta$ , except in a few places, and drop the  $i$  from the notation as before. Let  $E = E_r - i\frac{\Gamma}{2}$  be a resonance, that is, an eigenvalue of  $H_\beta$  with  $E_r \in \mathbb{R}$  and  $\Gamma > 0$  (of necessity,  $E$  is finitely degenerate). Recall that  $E$  is also an eigenvalue of  $H_{\tilde{\beta}}$  for  $\beta \leq \tilde{\beta} < \alpha$  and the eigenvectors correspond under  $\mathcal{U}(i(\tilde{\beta} - \beta))$ . A simple and important remark is that given  $\phi_0$  an eigenvector of  $H_\beta$  for  $E$ ,  $\phi_0$  does *not* lie in  $\text{Ran } \mathcal{U}(i\beta)$ , because, if we had  $\phi_0 = \mathcal{U}(i\beta)\phi_1$ ,  $\phi_1$  would be an eigenvector of  $H$  for the eigenvalue  $E$ , which is impossible, since  $E$  is non real.

Now, we can make the « change of representation » given by the operators  $\mathcal{U}(\theta)$ . If  $\theta \in \mathbb{R}$  and  $\psi \in \mathcal{H}$ ,  $\mathcal{U}(\theta)$  is unitary and:

$$\frac{d\psi}{dt} = -iH\psi \Rightarrow \frac{d\mathcal{U}(\theta)\psi}{dt} = -iH_\theta\mathcal{U}(\theta)\psi$$

For a complex  $\theta = i\beta$ , and  $\psi \in \mathcal{D}(\mathcal{U}(i\beta))$  at time  $t = 0$ , we still have:

$$\frac{d\psi}{dt} = -iH\psi \Rightarrow \frac{d\mathcal{U}(i\beta)\psi}{dt} = -iH_\beta\mathcal{U}(i\beta)\psi$$

because that is exactly what (iv) in the theorem of part 2 says. Bearing in mind the fact that we want to consider the eigenvectors of  $H_\beta$  for complex eigenvalues, which are not in  $\text{Ran } \mathcal{U}(i\beta)$ , we extend this equation to  $\frac{d\phi}{dt} = -iH_\beta\phi$ , the propagator of which, of course is just the semigroup  $e^{-itH_\beta}$ .

So far, we have done nothing new, from a purely mathematical point of view, but it seems fruitful, as we shall shortly see, to consider  $\mathcal{U}(i\beta)$  as an intertwining operator, as is done in (iv) of the theorem of part 2. In particular, if we consider the two body problem, we have:

$$H_\beta\psi = -e^{-2i\beta}\Delta\psi + V_\beta\psi$$

and, when  $\beta$  increases from  $\beta = 0$  to  $\beta = \frac{\pi}{4}$  (supposing  $V \in \mathcal{C}_\alpha$ ,  $\alpha > \frac{\pi}{4}$ ),

one can see that we have a *continuous* path from the time reversible Schrodinger equation to a diffusive equation (the operator  $H_{\pi/4}$  is not really accretive because of  $V_{\pi/4}$ , but at least, it looks like the heat operator). In fact, as soon as  $\beta > 0$ , the evolution becomes irreversible, which is a translation of the fact that  $e^{-itH_\beta}$  is a *semi*-group. For further evidences of this irreversibility, see below and [7].

We now turn to the definition of resonant states, which we first motivate: the operation of changing representation via  $\mathcal{U}(i\beta)$  is very much reminiscent of the strategy of the « nested Hilbert spaces », that is, for instance, by changing the weight factor of the measure which defines the square integrable functions, one can manage to recover new functions, in particular, one can include the plane waves in a new Hilbert space. In a little more general way, this trick enables to consider the « eigenstates » corresponding to « eigenvalues » of the continuous spectrum, to use more physical expressions. Similarly,  $\mathcal{U}(i\beta)$  makes it possible to look at new interesting states, namely the eigenstates of  $H_\beta$  for resonance eigenvalue, thus « completing », so to speak the Hilbert space. Coming back to the old representation, we can define states that are close to these new states, exactly as the nested Hilbert space would make it possible to define « nearly plane waves ».

Hence the definition:

DEFINITION. — Let  $H \in \mathcal{C}_\alpha$ ,  $\beta < \alpha$ ,  $E = E_r - i\frac{\Gamma}{2}$  a resonance (which we suppose, is simple, for simplicity), and  $\phi_0$  in the eigenspace for  $E$ :

$$H_\beta\phi_0 = E\phi_0$$

Then, for a positive  $\varepsilon$ , we say that  $\psi \in \mathcal{D}_\alpha$  is  $\varepsilon$ - $\beta$ -resonant if:

$$(1) \quad \|\mathcal{U}(i\beta)\psi - \phi_0\| \leq \varepsilon$$

We first note that  $\varepsilon$  can be taken arbitrary small, because is dense (exactly as there are square integrable functions arbitrarily close to plane waves, even if this sentence does not mean anything *inside*  $L^2(\mathbb{R}^3)$ ). We now describe these states more precisely, giving four specific properties; the first two are taken from [7].

i) Letting  $P_{(t)} \equiv |\langle \psi, e^{-itH}\psi \rangle|$  be the probability of remaining in the state  $\psi$  at time  $t$ , it is shown in [7] that:

$$P_{(t)} = Ce^{-\Gamma t} + \gamma(t) \quad (\gamma_{(t)} \text{ small})$$

This shows that a resonant state is something like a stationary state, displaying an « exponential decay » (this property comes back to the oldest ideas about resonances, life times, etc.)

ii) Let  $H(\omega) = H_0 + \omega V$  be a family of Hamiltonians, with  $H_0 \in \mathcal{C}_\alpha$ ,  $V \in \mathcal{C}_\alpha$  and  $\omega$  real close to zero. Suppose  $H_0$  has a simple isolated eigenvalue  $E$ . Then  $H_\beta(\omega)$  will have a resonance near  $E$  (independently of  $\beta$  and for suitable  $\omega$ ):

$$E(\omega) = E_r(\omega) - i \frac{\Gamma(\omega)}{2}$$

The following is proven in [7]:

**THEOREM (Simon).** — *If  $\Gamma(\omega) = -\Gamma_{2n}\omega^{2n} + \mathcal{O}(\omega^{2n+1})$ , the spectrum of  $H(\omega)$  is concentrated at precisely order  $(2n - 1)$  near  $E$ .*

We refer to M. M. M. P. XII, 5 for the definition of spectral concentration. Thus, the existence of a resonance imply a concentration in the spectrum, a notion which has an asymptotic meaning only — that is, one needs to consider one-parameter families of operators. However, this again connects resonances with old and physical ideas, like the construction of eigenstates corresponding to « eigenvalues of the continuous spectrum » (see also (iii) below for the connection with « pseudo-eigenvectors »).

iii) Here, we explicitly build-up resonant states. In conformity with (ii), they will be vectors with a narrow « spectral band », i. e. a narrow support in the spectral resolution of  $H$ . The construction itself adapts similar considerations in [7].

We do not suppose any more that  $E = E_r - i \frac{\Gamma}{2}$  is simple and let  $\phi$  be such that  $H_\beta \phi = E\phi$ .  $dE_\lambda$  denotes the spectral resolution of  $A$  (the progress operator) and  $d\Pi_\lambda$  that of  $H$ . Put:

$$(2) \quad \psi_n \equiv \int_{-n}^{\sqrt{n}} e^{-\lambda\beta} dE_\lambda \phi$$

where the end-points  $\sqrt{-n} \equiv \sigma_{(n)}^{\text{sup}}$  and  $-n \equiv \sigma_{(n)}^{\text{inf}}$  are arbitrary cut-off, with the conditions that:

$$\lim_{n \rightarrow \infty} \sigma_{(n)}^{\text{sup}} = - \lim_{n \rightarrow \infty} \sigma_{(n)}^{\text{inf}} = + \infty \quad \text{and} \quad \lim_{n \rightarrow \infty} \frac{\sigma_{(n)}^{\text{sup}}}{\sigma_{(n)}^{\text{inf}}} = 0$$

If  $\beta_0$  is the lowest value of  $\beta$  for which  $E$  remains an eigenvalue of  $H_\beta$  (i. e.  $E$  is swept off by the essential spectrum at  $\beta = \beta_0$ ), and if we denote by  $d\mu_\lambda$  the spectral measure  $d \langle E_\lambda \phi, \phi \rangle$ , the integral:

$$(3) \quad \int_{-\infty}^{+\infty} e^{2i\lambda t} d\mu_\lambda = \| \mathcal{U}(it)\phi \|^2$$

exists for  $(\beta_0 - \beta) < t < (\alpha - \beta)$ ; this suggests that:

$$d\mu_\lambda \sim e^{2\lambda(\beta - \beta_0)} d\lambda, \quad \lambda \ll 0, \quad \text{and} \quad d\mu_\lambda = e^{2\lambda(\beta - \alpha)} d\lambda, \quad \lambda \gg 0$$

a guess we will make (because unfortunately,  $d\mu_\lambda$  seems out of reach; most of the characterizations we have, including (i), are still somewhat non rigorous). Then:

$$\| \psi_n \|^2 \sim \int_{-n}^0 e^{2\beta_0 \lambda} d\lambda \sim C e^{2n\beta_0} \quad \text{and} \quad \mathcal{U}(i\beta)\psi_n = \phi + \eta_n, \quad \lim_{n \rightarrow \infty} \eta_n = 0.$$

that is,  $\psi_n$  is arbitrarily resonant when  $n$  increases. To study  $\psi_n$  with respect to the resolution  $d\Pi_\lambda$ , take  $(a, b)$  a small interval round  $E$ ; we want to compute:

$$(4) \quad \langle \psi_n, \Pi_{[a,b]}\psi_n \rangle = \lim_{\substack{\varepsilon \rightarrow 0 \\ \varepsilon > 0}} \frac{1}{2i\pi} \int_a^b \left\langle \psi_n, \left( \frac{1}{\lambda - i\varepsilon - H} - \frac{1}{\lambda + i\varepsilon - H} \right) \psi_n \right\rangle d\lambda$$

$$= \lim_{\substack{\varepsilon \rightarrow 0 \\ \varepsilon > 0}} \frac{1}{\pi} \text{Im} \int_a^b \langle \psi_n, (\lambda - i\varepsilon - H)^{-1} \psi_n \rangle d\lambda$$

That is:

$$\langle \psi_n, \Pi_{[a,b]}\psi_n \rangle = \frac{1}{\pi} \text{Im} \int_a^b \langle \mathcal{U}(-i\beta)\psi_n, (\lambda - H_\beta)^{-1} \mathcal{U}(i\beta)\psi_n \rangle d\lambda$$

$$= \| \psi_n \|^2 \cdot \frac{1}{\pi} \text{Angle}(a, E, b) + \frac{1}{\pi} \int_a^b \langle \mathcal{U}(-i\beta)\psi_n, (\lambda - H_\beta)^{-1} \eta_n \rangle d\lambda$$

using  $\mathcal{U}(i\beta)\psi_n = \phi + \eta_n$  and  $\langle \mathcal{U}(-i\beta)\psi_n, \phi \rangle = \| \psi_n \|^2$ .

The suggestive result is:

$$(5) \quad \lim_{n \rightarrow \infty} \frac{\langle \psi_n, \Pi_{[a,b]}\psi_n \rangle}{\langle \psi_n, \psi_n \rangle} = \frac{1}{\pi} \text{Angle}(a, E, b)$$

which shows how things behave when  $\Gamma$  gets smaller. To prove this equality, we use:

$$(6) \quad \lim_{n \rightarrow \infty} \eta_n = 0, \quad \| \mathcal{U}(-i\beta)\psi_n \| \leq e^{\beta\sqrt{n}} \| \psi_n \|^2$$

and

$$\|(\lambda - H_\beta)^{-1}\| \leq \frac{M}{\Gamma} \quad \text{for} \quad \lambda \in [a, b],$$

which is an other form of the evaluation (6 bis) in the second part (see also fig. 4). These properties show that in the computation of  $\langle \psi_n, \Pi_{[a,b]} \psi_n \rangle$  the first term on the r. h. s. dominates the second, as  $\|\psi_n\| \sim Ce^{n\beta_0}$  over  $e^{\beta\sqrt{n}}$ .

So, the more  $n$  increases, the more resonant  $\psi_n$  will be, and the more it is concentrated with respect to the spectral measure of  $H$ , provided  $\Gamma$  is small.

If one considers a one-parameter family  $H(\omega)$  of hamiltonians, like in (ii), the same construction yields vectors  $\Pi_{[a(\omega), b(\omega)]} \psi_n(\omega)$ . One can then show that, by adequately choosing  $a, b, n$  (namely such as they satisfy  $(b(\omega) - a(\omega)) \sim \omega^{1+\varepsilon}$  ( $0 < \varepsilon < 1$ ), which guarantees that the r. h. s. of (5) goes to  $I$  as  $\omega$  goes to 0), the construction furnishes a pseudo-eigenvector (see M. M. M. P. for the definition) for the family  $H(\omega)$ , thus connecting resonant states and spectral concentration again (\*).

iv) Let again  $E$  be simple, with unitary eigenvector  $\phi_0$  for  $H_\beta$ . Then, when the semi-group  $e^{-itH_\beta}$  is applied, we get  $\phi_{0(t)} = e^{-iEt} \phi_0$  and the square of the norm decreases like  $e^{-\Gamma t}$ . Let now  $\psi$  be resonant, and decompose it with respect to  $dE_\lambda$ :

$$\psi = \psi_{(0)} \equiv \psi_{(t=0)} = \int_{-\infty}^{+\infty} dE_\lambda \psi_{(0)}; \quad d\mu_\lambda^0 \equiv d\|E_\lambda \psi_{(0)}\|^2$$

$\psi$  satisfies the Schrödinger equation, hence, if  $d\mu_\lambda^t \equiv d\|E_\lambda \psi_{(t)}\|^2$ :

$$(7) \quad \|\psi_{(0)}\|^2 = \int_{-\infty}^{+\infty} d\mu_{(\lambda)}^0 = \int_{-\infty}^{+\infty} d\mu_{(\lambda)}^t = \|\psi_{(t)}\|^2$$

Now, if  $\|\mathcal{U}(i\beta)\psi_{(0)} - \phi_0\| \leq \varepsilon$ , we have:

$$(8) \quad \|\mathcal{U}(i\beta)\psi_{(t)} - \phi_0(t)\| \leq \|e^{-itH_\beta}\| \cdot \varepsilon \equiv C\varepsilon$$

where  $C$  can be evaluated, using the theorem of part 2; thus:

$$\|\mathcal{U}(i\beta)\psi_{(t)}\|^2 \leq e^{-\Gamma t} \|\mathcal{U}(i\beta)\psi_{(0)}\|^2 + 2C\varepsilon$$

or (9) 
$$\int_{-\infty}^{+\infty} e^{-2\lambda\beta} d\mu_{(\lambda)}^t \leq e^{-\Gamma t} \int_{-\infty}^{+\infty} e^{-2\lambda\beta} d\mu_{(\lambda)}^0 + 2C\varepsilon$$

So that, although  $\mu^0$  and  $\mu^t$  have the same mass, they behave differently, when integrating the functions  $e^{-2\lambda\beta}$  ( $0 < \beta < \alpha$ ) and everything looks like if the mass were translating at speed  $\Gamma/2\beta$ , measuring the « dissolution » of  $\psi$ .

These are the four characteristic properties we have, to describe the

---

(\*) I am grateful to the referee for pointing out a possible connection between resonant states and pseudo-eigenvectors.

specificity of the resonant states; of course, the last one will be their adiabatic invariance. Now, we need to consider a family  $H(t)$  of Hamiltonians in  $\mathcal{C}_\alpha$ , and the equation:

$$(10) \quad \frac{d\phi}{dt} = -iH_\beta(t)\phi$$

We first want to demonstrate the existence of a propagator  $S_\beta(t_0, t_1)$  ( $t_1 \leq t_0$ ) under mild hypotheses on the regularity of  $H(t)$ . This is done by applying a theorem of M. M. M. P. (X, 12), which we recall, rephrasing the hypotheses in a more concise, but equivalent form:

**THEOREM.** — *Let  $X$  be a Banach space,  $I$  an open interval in  $\mathbb{R}$ ; for  $t \in I$ , let  $A(t)$  be the generator of a contraction semigroup such that  $A(t)$  is invertible for every  $t \in I$  and:*

i) *The  $A(t)$  have a common domain  $\mathcal{D}$ .*

ii) *The map  $A$  from  $(I \times \mathcal{D})$  to  $X$ , given by  $A(t, \varphi) \equiv A(t)\varphi$  is  $\mathcal{C}^1$  with respect to the graph norm on  $\mathcal{D}$  (which is well defined because  $A_{(t)}A_{(s)}^{-1}$  is bounded on  $\mathcal{D}$ ).*

*Then, there exists a propagator  $\mathcal{U}(t, s)$ , i. e. if  $\psi \in \mathcal{D}$ ,*

$$\mathcal{U}(t, s)\psi \equiv \varphi_s(t) \in \mathcal{D}; \quad \frac{d\varphi_s}{dt}(t) = -A(t)\varphi_s(t)$$

moreover  $\|\varphi_s(t)\| \leq \|\psi\| \quad \forall t \geq s$

This readily applies to our case if we put:

$A(t) \equiv K + iH_\beta(t)$ ,  $K > 0$  large enough, where

$$H(t) = H_0 + \sum_{i < j} V_{ij}(t)$$

and the  $V_{ij}(t)$  are  $\mathcal{C}^1$  for  $t \in \mathbb{R}$ . We can find  $K$  large enough to apply the theorem on  $I \supset [0, 1]$  and then iterate to get  $S_\beta(t_0, t_1)$  for general  $(t_0, t_1)$  ( $t_1 \geq t_0$ ). We now look for a bound on  $S_\beta(t) \equiv S_\beta(0, t)$ ; remember that (iii) in the theorem of part 2 says that:

$$0 \leq \beta \leq \tilde{\beta}; \quad \|e^{-itH_\beta}\| \leq e^{M\beta t} \quad \text{with} \quad M = \frac{b(\tilde{\beta})}{\tilde{\beta}}$$

$b(\tilde{\beta})$  is obtained in the following way; for the two-body case:

$$H_\beta = -e^{-2i\beta}\Delta + V_\beta$$

and since  $V_\beta$  is  $\varepsilon$ - $\Delta$ -bounded as a quadratic form:

$$(11) \quad \forall \varepsilon, \exists b_\varepsilon, \quad |\langle \psi, \text{Im } V_\beta \psi \rangle| \leq \varepsilon |\langle \psi, \Delta \psi \rangle| + b_\varepsilon \|\psi\|^2$$

then  $b(\tilde{\beta}) \equiv b_\varepsilon$  for some chosen  $\varepsilon < \sin 2\tilde{\beta}$ . In the N-body case, just add

the results with  $\varepsilon < \frac{1}{N} \sin 2\tilde{\beta}$  (taking care of the masses if necessary).

Here,  $b(\tilde{\beta})$  will also depend on  $t$  and putting

$$b \equiv \sup_t b(\tilde{\beta}, t); \quad M \equiv \frac{b}{\tilde{\beta}}$$

one readily obtains the bound:

**PROPOSITION.** —  $\forall \beta, 0 \leq \beta \leq \tilde{\beta} < \alpha, \forall t \geq 0, \|S_\beta(t)\| \leq e^{M.\beta.t}$  showing the dependence with respect to  $t$  and  $\beta$ .

This is where we strongly needed an estimate of  $\|e^{-itH_\beta}\|$  for short intervals of time, and not only the fact that they are semigroups of type zero.

We now turn to the statement and proof of the adiabatical theorem.

#### 4) THE ADIABATIC INVARIANCE OF THE RESONANT STATES

Before stating our theorem, we recall briefly the content of the usual adiabatic theorem, as it was demonstrated by Kato in [8] (although many « non rigorous » derivations were given before — and after).

Let  $H_{(s)}$  ( $s \in [0, 1]$ ) be a family of self-adjoint operators in a Hilbert space  $\mathcal{H}$ , such that there is an eigenvalue  $\lambda(s)$  of  $H(s)$  isolated and finitely degenerate for every  $s$ , with spectral projection  $\Pi(s)$ . We suppose that  $\lambda(s)$  and  $\Pi(s)$  are of class  $\mathcal{C}^2$  (of necessity,  $\dim \text{Ran } \Pi(s)$  is a constant) and consider the equation:

$$(1)_\tau \quad \frac{d\psi}{ds} = -i\tau H(s)\psi$$

We refer to the last paragraph as for the existence of a propagator for this equation.  $\tau$  is a positive number which plays the role of a characteristic time, that is,  $s$  is dimensionless and  $\tau s$  is the time variable; we leave it to the reader to convince himself that letting  $\tau$  tend to infinity is the same thing as looking to the Schrödinger equation, between times  $t = 0$  and  $t = \tau$ , with a parameter more and more slowly varying, as  $\tau$  gets larger:

**ADIABATIC THEOREM.** — *Let  $\psi_0 \in \text{Ran } \Pi(0)$  and  $\psi_\tau(s)$  satisfying (1) $_\tau$  with:*

$$\psi_\tau(0) = \psi_0 \quad \forall \tau$$

*then:*

$$(2) \quad \sup_{s \in [0, 1]} \|\psi_\tau(s) - \Pi(s)\psi_\tau(s)\| = \mathcal{O}\left(\frac{1}{\tau}\right)$$

That is, for a slowly varying parameter, and starting from an eigenvector for  $\lambda(0)$ , the solution of the Schrödinger equation « follows » the eigenspace  $\text{Ran } \Pi(s)$ . Our ultimate goal is to generalize this theorem to

resonant states (obeying the Schrödinger equation), to this end, we consider a family  $H(s)$  of Hamiltonians in  $\mathcal{C}_\alpha$ , obeying the conditions stated in the existence theorem of the last paragraph, and the equation:

$$(*) \quad \frac{d\psi}{ds} = -i\tau H_\beta(s)\psi$$

with a propagator  $S_{\beta,\tau}(s)$  between 0 and  $S$ , satisfying:

$$(3) \quad \|S_{\beta,\tau}(s)\| \leq e^{M\tau s}$$

for some constant  $M$  (independent of  $\tau$  as is easily seen).

We make the further hypothesis, analogous to that of the usual theorem, that for some  $\beta_0$  (hence for any  $\beta \in [\beta_0, \alpha]$ ) there exists a resonance  $E(s) = E_r(s) - i\frac{\Gamma(s)}{2}$ , isolated in the spectrum of  $H_{\beta_0}(s)$  for every  $s \in [0, 1]$ , and of — constant — multiplicity  $n$ . As one can see on figure 4:

$$\text{tg } 2\beta_0 > \sup_{s \in [0,1]} \frac{\Gamma(s)}{2(E_r(s) - \Sigma(s))}$$

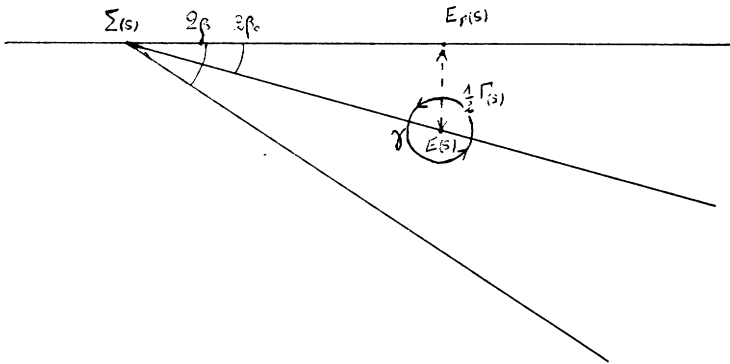

FIG. 4.

where  $\Sigma(s)$  is the nearest threshold; as we will shortly see, we will need to have  $\Gamma \equiv \sup \Gamma(s)$  and  $\beta_0$  very small, i. e. an acute resonance not to close to a threshold, two conditions that do not look unphysical.

The situation is best described by the following diagram:

$$(4) \quad \begin{array}{ccc} \mathcal{D}(\mathcal{U}(i\beta)) & \xrightarrow{(S, E)} & \mathcal{D}(\mathcal{U}(i\beta)) \\ \mathcal{U}(i\beta) \downarrow & & \downarrow \mathcal{U}(i\beta) \\ \mathcal{H} & \xrightarrow{(*)} & \mathcal{H} \end{array}$$

which depicts our strategy: we are concerned with proving the adiabatic stability of the resonant states, which are physical states, evolving according to the Schrödinger Equation (S. E.). However, to this end, we shall in fact demonstrate the adiabatic stability of the eigenvectors for the resonance  $E(s)$ , which evolve according to (\*) and are much easier to deal with mathematically speaking, but *cannot* be studied, using the Schrödinger equation, since they are *not* in  $\text{Ran } \mathcal{U}(i\beta)$ . Once this is done, the following conclusions can be drawn:

— Start with a resonant state  $\psi$ , i. e. a vector in  $\mathcal{D}_\alpha$  ( $\alpha > \beta$ ) such that  $\|\mathcal{U}(i\beta)\psi - \phi_0\| < \varepsilon$  for some small  $\varepsilon$ .

— Go down the left vertical arrow and study the time evolution of  $\phi_0 \equiv \phi(0)$  under (\*).

— The adiabatic theorem proven below tells you that if the Hamiltonian has slowly varying parameters, you end up at time  $\tau$  with a vector  $\phi(1)$  (recall  $t \equiv \tau s$ ) close to  $\phi_1$ , the eigenvector of  $H_\beta(1)$ , for the resonance  $E(1)$ .

— If  $S_\beta$  denotes the evolution operator of (\*),  $\mathcal{U}(i\beta)\psi$  evolves in  $S_\beta\mathcal{U}(i\beta)\psi$  and stays in  $\text{Ran } \mathcal{U}(i\beta)$  as shows the part (iv) of the theorem in the second part. In fact  $S_\beta\mathcal{U}(i\beta)\psi \equiv \mathcal{U}(i\beta)\psi(s)$  where  $\psi(s)$  satisfies the Schrödinger equation; now:

$$\begin{aligned} \|\mathcal{U}(i\beta)\psi_{(1)} - \phi_1\| &\leq \|S_\beta(1)\| \cdot \|\mathcal{U}(i\beta)\psi_0 - \phi_0\| + \\ &\quad + \|\phi_{(1)} - \phi_1\| \leq \varepsilon \|S_\beta(1)\| + \|\phi_{(1)} - \phi_1\| \end{aligned}$$

the second quantity on the r. h. s. is small by the adiabatic theorem for  $\phi$  and the first is small if  $\|S_\beta\|$  is not too large. Unfortunately, our estimation on  $\|S_\beta\|$  is not sharp enough to make sure that this holds in the general case. Hence, with this proviso, which cannot be avoided, although it is very likely to hold in almost all cases of interest, this shows that  $\psi_{(1)}$  is a resonant state, and so that resonant states can be claimed to be adiabatically invariant.

We now return to the statement of the theorem:

**THEOREM (A).** — *Let (\*) be the equation:*

$$\frac{d\psi}{ds} = -i\tau H_\beta(s)\psi \quad (\beta > \beta_0 \text{ will stay fixed in the following})$$

*with an isolated resonance  $E(s)$  of constant multiplicity  $n$ , and associated spectral projection  $\Pi_\beta(s)$ :*

$$\Pi_\beta(s) = \frac{1}{2\pi i} \int_\gamma (\lambda - H_\beta(s))^{-1} d\lambda \quad (\text{see figure 4})$$

$$\text{We set: } \rho \equiv \sup_{s \in [0,1]} (\|\Pi_\beta(s)\|^2 - 1)^{\frac{1}{2}}; \quad \rho_1 = \sup_{s \in [0,1]} \left\| \frac{d\Pi_\beta(s)}{ds} \right\|$$

Let  $\phi_0 \in \Pi_\beta(0)$ , and  $\phi_\tau(s)$  satisfying (\*) for the value  $\tau$  of the parameter and  $\phi_\tau(0) \equiv \phi_0 (\forall \tau)$ ; then:

$$(5) \quad d(\phi_\tau(1), \Pi_\beta(1)) \leq 2n\rho + \left[ e^{A_0\beta\tau} - e^{-2n\rho\tau} \left( 1 - A_1 \frac{e^{A_0\beta\tau}}{\tau} \right) \right]^{\frac{1}{2}}$$

where  $d(\phi_\tau(1), \Pi_\beta(1))$  denotes the distance of  $\phi_\tau(1)$  to the subspace  $\Pi_\beta(1)$  (from now on, we make no notational distinction between a projector and his range, when the context is clear), and  $A_0$  and  $A_1$  are two constants to be computed below.

Before we prove anything, we make a few remarks about what this formula really means:

i) We look only at what happens at time  $\tau$  ( $s = 1$ ) because this is really no loss of generality.

ii) We need nearly orthogonal projections ( $\rho$  small) and small  $A_0$  and  $A_1$  for this inequality to be really what we want it to be; this will be achieved in particular in the perturbative version to be stated below; generally speaking, there cannot be « universal constants », just like for instance, the convergence of a Fourier series.

iii) The adiabatical stability will take place for values of  $\tau$  which are « large », but still, much smaller than the « lifetime »  $\Gamma^{-1}$ , after which the considered resonant states are dissolved. This is precisely what you expect, and does not pose any special problem to the physicist; in actual experiments, « infinitely slowly » can mean « within  $10^{-5}$  s », so, different scales of time will take place (perhaps all this could be rephrased, using non-standard analysis!). As a good illustration of this, look at the function  $e^{\Gamma\tau} \cdot \tau^{-1}$  for small  $\Gamma$  (see figure 5, this function will be characteristic

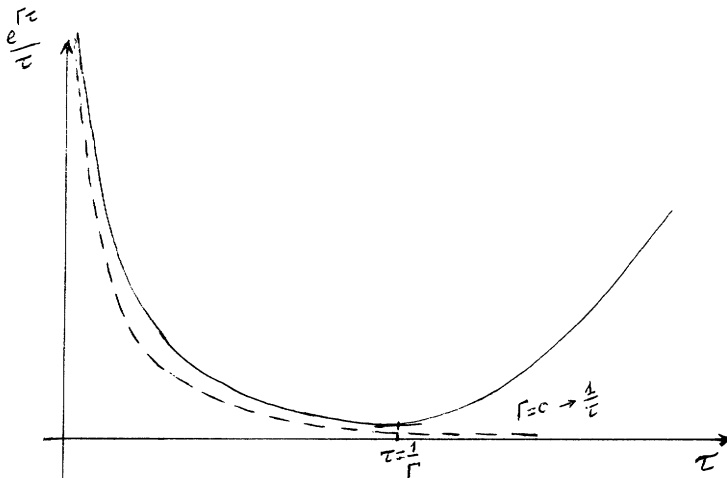

FIG. 5.

in the following formulas), one keeps track of the phenomenon until something like the lifetime, and then, it gets out of control.

We now turn to the proof of (5). First, one can suppose that  $E(s) \equiv 0$ , because this amounts to multiplying the solutions of (\*) by

$$\exp \left[ -i\tau \int_0^s E(u) du \right];$$

this is not, however, a completely innocent operation, because  $\|\psi(s)\|^2$  is multiplied by  $\exp \left[ \tau \int_0^s \Gamma(u) du \right] \geq \exp \Gamma \tau s$  and so, we denote by  $\tilde{S}_{\beta, \tau}$  the propagator of:

$$(\tilde{*}) \quad \frac{d\phi}{ds} = -i\tilde{H}_\beta(s)\phi; \quad \tilde{H}_\beta(s) \equiv H_\beta(s) - E(s)$$

and will put the phase factor again at the end. Next, we drop the subscript  $\beta$ , which is a fixed number ( $\beta_0 < \beta < \alpha$ ) throughout.

Now, let  $W$  be the solution of:

$$(6) \quad \frac{dW}{ds} = \frac{d\Pi^*}{ds} \cdot W \quad \text{and} \quad W(0) \equiv \Pi_{(0)}^*$$

(the star denotes the adjoint operator).

One can check that  $W = \Pi^*W$ , because using  $\Pi^* \frac{d\Pi^*}{ds} \Pi^* = 0$ , it is easy to prove that in fact,  $W = \Pi^*Z$  with:

$$(7) \quad \frac{dZ}{ds} = \left[ \Pi^*, \frac{d\Pi^*}{ds} \right] \cdot Z \quad \text{and} \quad Z(0) = \mathbb{1}$$

Of course,  $W$  does not depend on  $\tau$  and we can write:

$$\begin{aligned} \forall \varphi \in \mathcal{H}; \quad \frac{d\|W\varphi\|^2}{ds} &= 2\operatorname{Re} \left\langle \frac{d\Pi^*}{ds} W\varphi, W\varphi \right\rangle \\ &= 2\operatorname{Re} \left\langle (\Pi - \Pi^*) \frac{d\Pi^*}{ds} \varphi, W\varphi \right\rangle \end{aligned}$$

which shows that:

$$(8) \quad \|W(s)\| \leq e^{\rho^{1, \alpha, s}}; \quad \alpha \equiv \sup_{s \in [0, 1]} \|(\Pi(s) - \Pi^*(s))\|$$

as for the relationship between  $\alpha$  and  $\rho$ , we use the

LEMMA. — Let  $\Pi$  be a projector, with  $n$ -dimensional range, and let  $\|\Pi\|^2 = 1 + \rho^2$ , then:

$$\|\Pi - \Pi^*\| \leq 2n\rho$$

that is  $\alpha \leq 2n\rho$ .

*Proof of the lemma.* — First, we take  $n=1$ , then, there exist  $\varphi_0$  and  $\varphi_1$  such that:

$$\forall \varphi \in \mathcal{H}, \quad \Pi\varphi = \langle \varphi_0, \varphi \rangle \varphi_1, \quad \|\varphi_1\| = 1, \quad \langle \varphi_0, \varphi_1 \rangle = 1.$$

writing  $u = \varphi_0 - \varphi_1$ , we have:

$$\langle u, \varphi_1 \rangle = 0 \quad \text{and} \quad \|u\| = \rho \quad (\text{since } \|\Pi\| = \|\varphi_0\|).$$

Hence:

$$\begin{aligned} \|(\Pi - \Pi^*)\varphi\| &= \|\langle \varphi_0, \varphi \rangle \varphi_1 - \langle \varphi_1, \varphi \rangle \varphi_0\| \\ &= \|\langle u, \varphi \rangle \varphi_1 - \langle \varphi_1, \varphi \rangle u\| \leq 2\|u\| \cdot \|\varphi\| \end{aligned}$$

For arbitrary  $n$ , write:

$$\Pi\varphi = \sum_{i=1}^n \langle \psi_i, \varphi \rangle \varphi_i;$$

$(\varphi_i)_{i=1}^n$  orthonormal and  $\langle \varphi_i, \psi_i \rangle = 1, \forall i$ . Then:

$$\|\Pi - \Pi^*\| \leq \sum_{i=1}^n \|\Pi_i - \Pi_i^*\| \quad \text{with} \quad \Pi_i\varphi \equiv \langle \psi_i, \varphi \rangle \varphi_i$$

The result follows from the one dimensional case, observing that  $\|\Pi_i\| \leq \|\Pi\|$ .

We now compute:

$$\frac{d}{ds}(\tilde{S}^*W) = \tilde{S}^* \frac{dW}{ds} + i\tau \tilde{S} \cdot \tilde{H}^*W = \tilde{S}^* \frac{dW}{ds} \text{ since } W = \Pi^*W \text{ and } \tilde{H}^*\Pi^* = 0.$$

$$\text{Moreover: } \tilde{S}^* \frac{dW}{ds} = \tilde{S}^*(1 - \Pi^*) \frac{dW}{ds} \text{ because } \Pi^* \frac{dW}{ds} = 0.$$

But we can write:  $(1 - \Pi^*) = \tilde{H}^*R = R\tilde{H}^*$  for some bounded operator  $R$ ; this is because  $H$  (or  $H^*$ , or  $\tilde{H}^*$ ) is a spectral operator with an isolated eigenvalue  $E(s)$  (alternatively, 0 is isolated in the spectrum of  $\tilde{H}$ ). From this, we deduce:

$$(9) \quad \tilde{S}_{(1)}^*W(1) = \Pi_{(0)}^* + \int_0^1 \tilde{S}^* \frac{dW}{ds} ds = \Pi_{(0)}^* + \frac{1}{i\tau} \int_0^1 \frac{d\tilde{S}^*}{ds} \cdot R \frac{dW}{ds} ds$$

with the estimate:  $\|\tilde{S}_{(s)}^*\| \leq \exp\left(M\beta + \frac{1}{2}\Gamma\right)\tau s \equiv \exp A_0\beta\tau s$ .

integrating by parts, we get:

$$(10) \quad \tilde{S}_{(1)}^*W(1) = \Pi_{(0)}^* + \frac{1}{i\tau} \tilde{S}^* \cdot R \frac{dW}{ds} \Big|_0^1 - \frac{1}{i\tau} \int_0^1 \tilde{S}^* \cdot \frac{d}{ds} \left( R \cdot \frac{dW}{ds} \right) ds.$$

Hence, if  $\phi_{(0)} \in \Pi_{(0)}$ ,  $\|\phi_0\| = 1$ , the following inequality holds:

$$(11) \quad | \langle \tilde{S}(1)\phi_0, W(1)\phi_0 \rangle - 1 | \leq A_1 \cdot \tau^{-1} \cdot \exp(A_0\beta\tau).$$

where  $A_1$  stands for  $\sup_{s \in [0,1]} \left\| \frac{d}{ds} \left( R \frac{dW}{ds} \right) \right\|$  (this is the very expression one comes across when proving the usual theorem) and does not depend on  $\tau$ . We now estimate the distance between  $\tilde{\phi}_\tau(1) \equiv \tilde{S}_\tau(1)\phi_0$  and  $\Pi(1)$ ; the same estimate will hold for  $\phi_\tau(1)$ , which is proportional and shorter. Obviously:

$$(12) \quad d(\tilde{\phi}_\tau(1), \Pi(1)) \leq d(\tilde{S}(1)\phi_0, \Pi_{(1)}^*) + d(\Pi(1), \Pi_{(1)}^*)$$

the lemma gives an estimate of the second term on the r. h. s.; as for the first:

$$d^2(\tilde{S}(1)\phi_0, \Pi_{(1)}^{**}) = \inf_{\Phi \in \Pi_{(1)}^*, \|\Phi\|=1} (\|\tilde{S}(1)\phi_0\|^2 - \langle \tilde{S}(1)\phi_0, \Phi \rangle)$$

as a test vector, we take  $\Phi \equiv (\|W(1)\phi_0\|)^{-1} \cdot W(1)\phi_0$  wherefrom we obtain, by the evaluations (8) and (11):

$$(13) \quad d^2(\tilde{\phi}_\tau(1), \Pi_{(1)}^*) \leq e^{A_0\beta\tau} - e^{-2n\rho\tau}(1 - A_1\tau^{-1}e^{A_0\beta\tau})$$

which proves the evaluation of the theorem. ■

The last thing we want to do is to give a perturbative version of this. To this end, we consider a family  $H(\omega, s)$  of Hamiltonians, all in  $\mathcal{C}_x$ , such that  $H(\omega, s)$  is an analytic family in the sense of Kato for any fixed  $s$  (one can think of  $H(\omega, s) = H_0(s) + \omega V(s)$  where  $V$  may be a sum of interacting potentials). We suppose further that  $H_0(s) \equiv H(0, s)$  has an eigenvalue  $E_0(s)$  embedded in the continuum. Then  $H_\beta(\omega, s)$  exists and will possess a resonance for sufficiently small  $\omega$ :

$$E(\omega, s) = E_r(\omega, s) - i \frac{\Gamma(\omega, s)}{2}$$

As an example, one can think of the helium atom without interaction between the two electrons for  $H_0 - \omega$  would then be the coupling constant.

We again suppose that the multiplicity is constant (no bifurcation) and we add the letter  $\omega$  to all the previous notations to emphasize the dependance on this parameter.

**THEOREM (B).** — *Let (\*) be the equation:*

$$(*) \quad \frac{d\phi}{ds} = -i\tau H_\beta(\omega, s)\phi$$

and we suppose the following is fulfilled:

— *There exists  $\tilde{\tau}$  such that for  $\beta$  and  $\omega$  small enough, the propagator  $S_{\beta, \omega, \tau}(s)$  is a contraction operator for  $\tau \geq \tilde{\tau}$ .*

*Then:  $\forall \eta > 0, \exists(\beta, \omega_0, \tau_0, \tau_1)$  such that  $0 < \tilde{\tau} < \tau_0 < \tau_1$  and the following takes place:*

$\forall \omega < \omega_0, \forall \phi_0 \in \Pi_\beta(\omega, 0)$ , denoting by  $\phi_\tau(s)$  the solution of (\*) with initial value  $\phi_0$  ( $\phi_\tau(0) = \phi_0, \forall \tau$ ) one has:

$$(15) \quad \forall \tau \in [\tau_0, \tau_1] \quad d(\phi_\tau(1), \Pi_\beta(\omega, 1)) < \eta$$

This is really the sort of things you expect and which is easy to show, using the estimate of theorem (A) which yields, using the extra hypothesis:

$$d(\phi_\tau(1), \Pi_\beta(\omega, 1)) \leq \left\{ 1 - e^{-2n\rho\tau} \left[ 1 - \tau^{-1} \exp\left(\frac{1}{2} \Gamma(\omega)\tau\right) \right] \right\}^{\frac{1}{2}} + 2n\rho$$

where of course:  $\Gamma(\omega) \equiv \sup_{s \in [0,1]} \Gamma(\omega, s), \rho \equiv \rho(\beta, \omega)$ .

Notice that  $\Pi_\beta(\omega, s)$ , associated to  $E(\omega, s)$  is analytic with respect to  $\beta$  and  $\omega$ , and  $\Pi_0(0, s)$  is orthogonal for every  $s$  ( $\|\Pi_0(0, s)\| = 1$ ); so, chose first  $\beta$  so that  $\rho(\beta, 0) \equiv \sup_s (\|\Pi_\beta(0, s)\|^2 - 1)^{\frac{1}{2}}$  is small enough and then, chose  $\omega$  such that both  $\rho(\beta, \omega)$  and  $\Gamma(\omega)$  are again small. This can be done for arbitrary  $\eta$ , and yields the inequality (15).

### BIBLIOGRAPHIE

- [1] G. LOCHAK, in *Dynamical systems and microphysics*, Courses and Lectures of the International Center for Mechanical Sciences, n° 261, Springer Ed. (Vienna).  
G. LOCHAK and A. ALAOUL, in *Annales de la Fondation Louis de Broglie*, t. 2, 2, Paris, 1977.
- [2] See above and also: G. LOCHAK, *C. R. A. S.*, « Comptes Rendus » of the French Academy of Sciences. Série B, t. 275, 1972, p. 49.
- [3] M. REED and B. SIMON, *Methods of Modern Mathematical Physics*, t. I to IV, Academic Press. We quote « M. M. P. + chapter and paragraph ».
- [4] J. AGUILAR and J. M. COMBES, A class of analytic perturbations, *Comm. in Math. Phys.*, t. 22, 1971, p. 269-279.  
E. BALSLEV and J. M. COMBES, Spectral properties of many-body Schrödinger operators with dilation analytic interactions. *Comm. Math. Phys.*, t. 22, 1971, p. 280-294.
- [5] This is in fact the paper quoted above.
- [6] D. BABITT and E. BALSLEV, *Journal of Functional Analysis*, t. 18, 1975, p. 1.
- [7] B. SIMON, Time dependent perturbation theory, *Annals of Maths*, t. 97, 1973, p. 247.
- [8] T. KATO, *Journal of the Phys. Soc. of Japan*, 1950, p. 435.

(Manuscrit reçu le 10 juin 1982)

(Version révisée reçue le 3 janvier 1983)